

PHOENIX 20 FLOOR SCRUBBER BRUSH DRIVE



Technical Specifications

Model Phoenix 20 Floor Scrubber Brush Drive
Model No. 3336604QP / PHX20BD / PHX20BDQP / PHX20BDQP6

Current (Max)	32 amps
Battery Capacity (Lead Acid)	105Ah @20 hr
Battery Capacity (Gel)	95Ah @20 hr
Sound Level	69 dBA
Cleaning path width	20 in (51 cm)
Squeegee width	33 in (84 cm)
Theoretical productivity (Brush Drive)	15,000 ft ² /hr (1,394 m ²)
Working speed (Brush Drive)	1.7 mph (2.7 km per hr)
Transport speed	3 mph (4.8 km per hr)
Rated voltage	24 volts
Vacuum flow	65 cfm (110 m3/hr)
Vacuum waterlift	45 inches (112mbar)
Vacuum power	.60 HP (450 W)
Brush type	Disc
Brush motor(s) power	3/4 HP (560W)
Number of brushes	1
Brush RPM	180 RPM
Aqua-Stop equipped	Coming Soon
Solution capacity	12 Gal (45 liters)
Recovery capacity	13 Gal (49 liters)
Working Grade	2%
Weight with batteries	313 lbs (142 kg)
Weight without batteries	203lbs (92 kg)
Dimensions (LxWxH)	47.4 x 21.3 x 42.3 (120.4 x 54.1 107.4 cm)

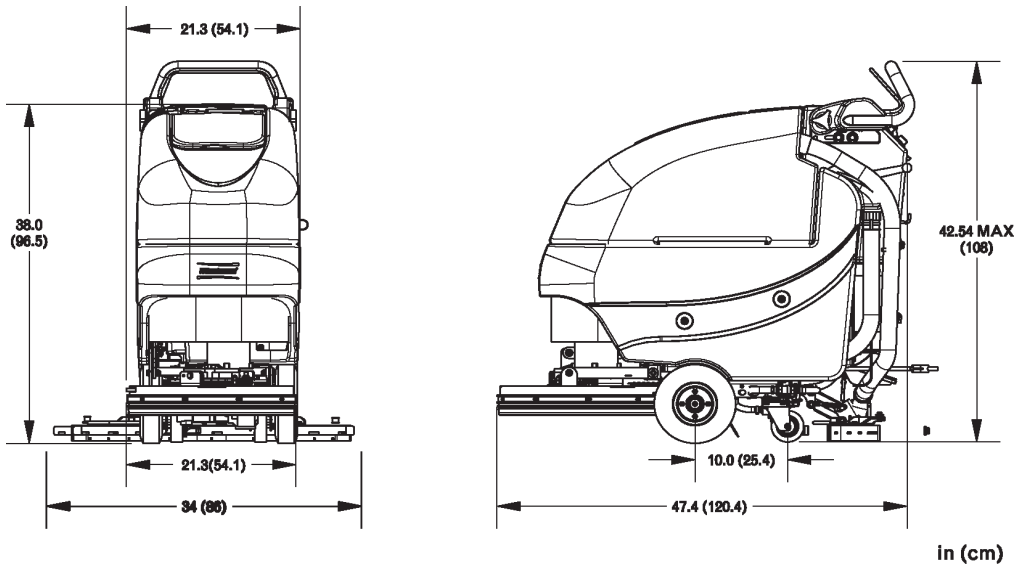

For Safety When Servicing or Maintaining Machine

- Stop on level surface.
- Disconnect the power to the machine by pulling the red Battery Connector located under the recovery tank near the batteries.
- Avoid moving parts. Do not wear loose jackets, shirts, or sleeves when working on machine.
- Avoid contact with battery acid. Battery acid can cause burns. When working on or around batteries, wear protective clothing and safety glasses. Remove metal jewelry. Do not lay tools or metal objects on top of batteries.
- Do not clean machine with a pressure washer.
- Authorized personnel must perform repairs and maintenance. Use PowerBoss supplied replacement parts.

Table of Contents

Main Assembly	1
Main Assembly BOM	2
Brush Drive Base Assembly	3
Brush Drive Base Assembly BOM	4
Base Assembly	5
Chassis Assembly	6
Chassis Assembly BOM	7
Solution Valve Assembly	8
Solution Tank Assembly	9
Lift Pedal Stop Assembly	10
Recovery Tank Assembly	11
Recovery Tank Assembly BOM	12
Handle Assembly	13
Battery Tray Assembly	14
Electrical Box Assembly	15
Electrical Box Assembly BOM	16
Electrical Box Cover Assembly	17
Vac Motor Assembly	18
20" Brush Deck Assembly	19
20" Brush Deck Assembly BOM	20
Brush Hub Assembly	21
Rear Squeegee Assembly	22
Squeegee Mechanism Assembly	23
Wiring Diagrams	24
WARRANTY	27

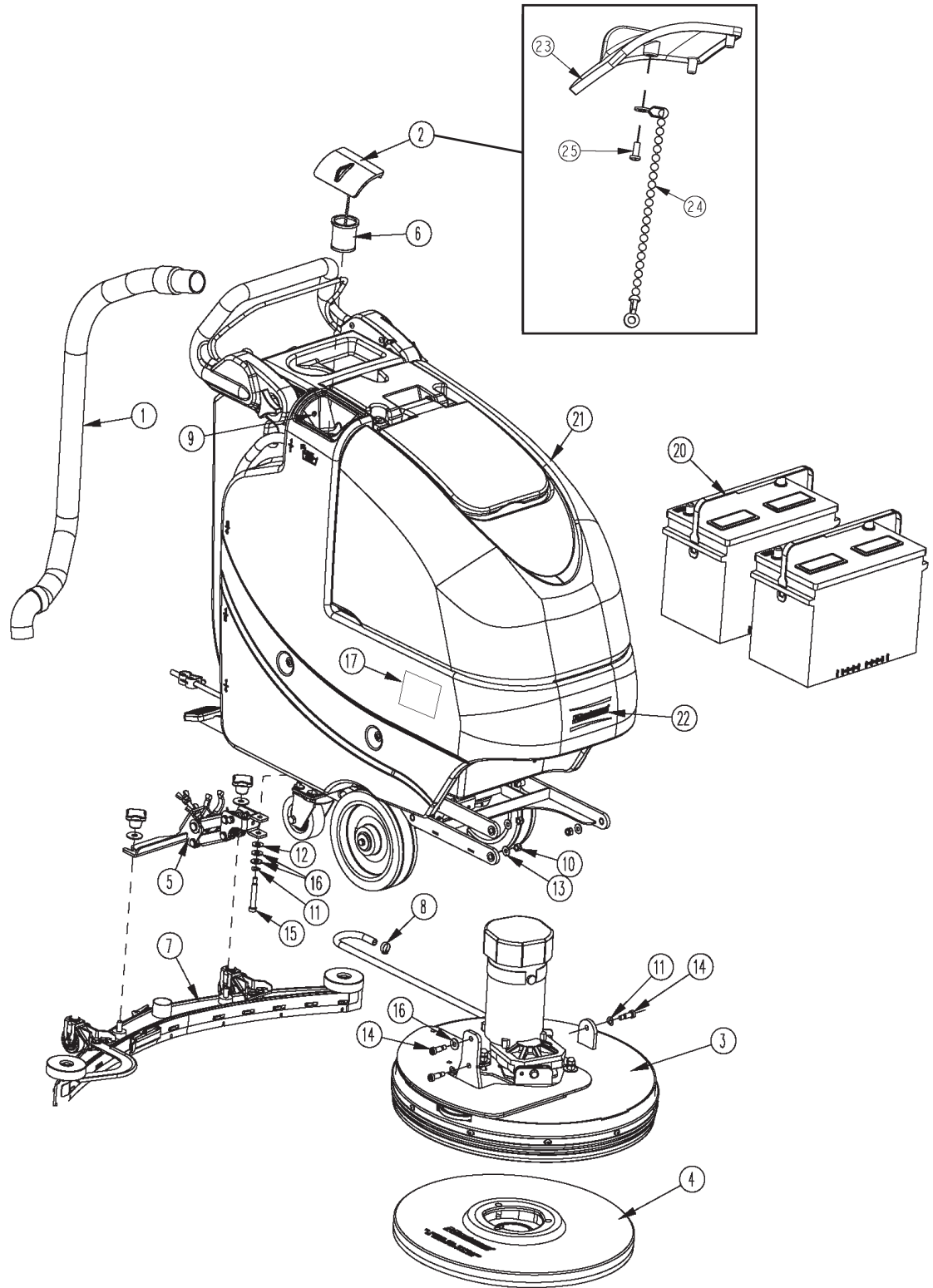

BILL OF MATERIAL			
ITEM	PART NO.	REQ'D	DESCRIPTION
1	172010	1	HOSE, CLEAR VAC W/ 45 CUFF
2	172018	1	SOLUTION TANK LID ASSY
3	172100	1	BRUSH DECK ASSY 20"
4	172120-2	1	20" PAD DRIVER - 120V
5	172150	1	SQUEEGEE LIFT MECH ASSY
6	172159	1	FILTER, FILL PORT
7	172270	1	SQUEEGEE, 34" (860)
8	450076	1	CLAMP-CRIMP 185R SS
9	711118	1	SCR-ST-A 10 X .75 SS
10	711374	3	NUT-NYLOC 5/16-18
11	711523	3	WSR-WAVE .37X.68 X .08
12	711569	1	WSR-FLT .390 X .880 X .062 NYL
13	711575	3	WSR-FLT .31x.75x.06ST
14	712081	3	SHOULDER BLT 5/16-18 X 3/8 X .75
15	712143	1	BLT-SHLD 3/8 X 2.0, 5/16-18
16	712301	3	WSR-FLAT .37 X .87 X .06
17	715688	2	DECAL, PHOENIX
18	740164-1	1	JUMPER CABLE ASSY, RED 4G 12"
19	747649	1	CABLE ASSY, BATTERY
20	956712	2	BATTERY, 12V 115AH
21	172001BD-120	1	BRUSH DRV MAIN ASSY-120V CHARGER
22	3334902	1	DECAL, POWERBOSS
23	172008	1	SOLUTION TANK LID
24	172123	1	CHAIN, BEADED SS W/ EYELETS
25	712145	1	SCR-MC 6-32 X .37 PPH SS

OPTIONAL BRUSHES		
ITEM	PART NO.	DESCRIPTION
4.1	172120-1	BRUSH, 20" NYLON
4.2	172120-3	BRUSH, 20" POLY GRIT
4.3	172120-4	BRUSH, 20" STRATA GRIT
4.4	172120-5	BRUSH, 20" DYNA-SCRUB 500GR

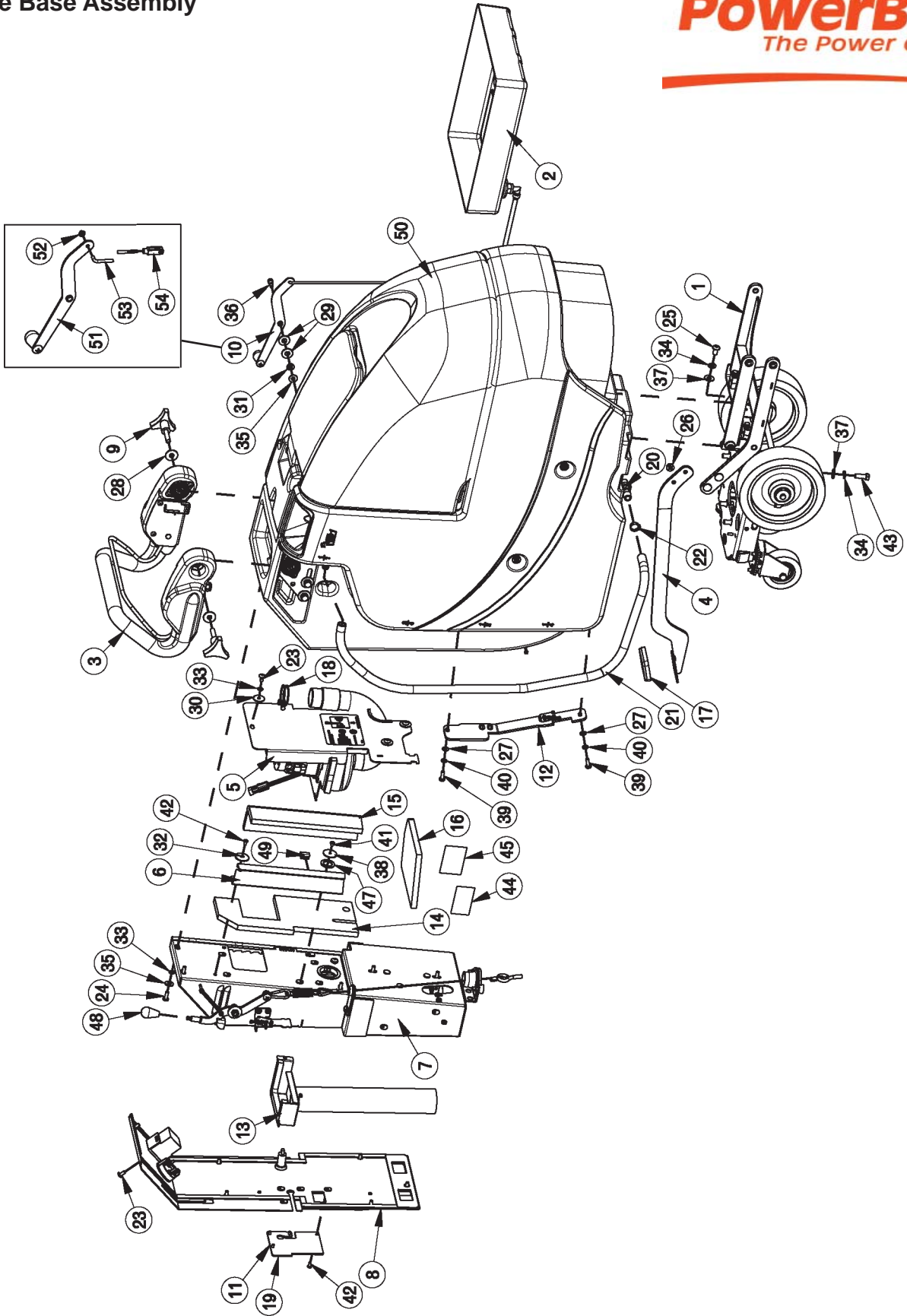

BILL OF MATERIAL - 172001BD-120							
ITEM	PART NO.	REQ'D	DESCRIPTION	ITEM	PART NO.	REQ'D	DESCRIPTION
1	172002-1	1	BD CHASSIS ASSY	28	711507	2	WSR-FLAT .37 X 1.12 X .06
2	172012	1	BATTERY TRAY ASSY	29	711508	2	WSR-FLAT .44X 1.0X.08
3	172016	1	BD HANDLE ASSY	30	711519	3	WSR- FLAT .25 X 1.01 X .06
4	172032	1	LIFT PEDAL WMT	31	711523	1	WSR-WAVE .37X .68 X .08
5	172050	1	VAC MOTOR ASSY	32	711543	1	WSR-HELICAL #10
6	172055	1	BKT, VAC AREA INSIDE COVER	33	711544	9	WSR-HELICAL 1/4
7	172070-120	1	ELEC BOX BD ASSY 120V	34	711546	6	WSR-HELICAL 3/8
8	172073	1	BD ELEC BOX COVER ASSY	35	711575	6	WSR-FLT .31x.75x..06ST
9	172085	2	KNOB, 3/8-16 STUD, 3 LOBE	36	712041	1	BLT- SHLDR 1/4-20 X .44 X .37
10	172112	1	SOL CONTROL ASSY	37	712301	6	WSR-FLAT .37 X .87 X .06
11	172129	1	BKT, PWR CORD MOUNT	38	712312	2	WSR-FLAT .187 X 1.25
12	172157	1	LIFT PEDAL STOP ASSY	39	712562	2	BOLT-HH 1/4-20X3/4 SS
13	172179	1	CHARGER INLET ASSEMBLY	40	712758	2	WSR-HELICAL 1/4 SS
14	172184	1	FOAM COVER, REAR 1	41	712800	1	SCR-MC 10-24 X .25 ST PL
15	172185	1	FOAM COVER, REAR 2	42	712810	5	SCR-MC 10-24 X .37 ST PL
16	172187	1	FOAM COVER, FRONT 2	43	713042	4	BLT-HH 3/8-16 X 1 #5
17	210142	1	PEDAL PAD	44	715029	1	DECAL-NAME PLATE SERIAL
18	260203	1	WIRE GRIP HOSE CLAMP	45	715047	1	DECAL-CLEAR LAMINATE 2X3
19	293080	1	STRAIN RELIEF-HEYCO 1207	46	715950	1	LABEL, PATENT NUMBERS
20	342440	1	FITTING, TEE 3/4MPT 1/2BARB PP	47	717025	1	WSR-FLAT 13/16ID X 1.25 X .08
21	430156	1	HOSE, 1/2 X 42 CLEAR	48	760592	1	KNOB, OVAL TAPERED
22	450093	2	CRIMP CLAMP 3/4" STEPLESS	49	809443	1	CLIP-WIRE & CORD
23	710178	10	SCR-MC 1/4-20 X .50 TRUSS STPL	50	172001BASE	1	BASE ASSY
24	710380	5	SCR-MC RD HD 1/4-20 X .75 STL PL	51	172115	1	SOL CNTRL LEVER ASSY
25	710985	2	SCR-SC 3/8-16 X .62 ST PL	52	172122	1	NUT, PUSH-ON WSR CAP, 3/16
26	711379	2	NUT, FLANGED WIZZ 5/16-18	53	172069	1	ROD, SOL. CTRL
27	711504	2	WSR-FLAT 1/4 ID SS	54	172062	1	YOKE, 3/16 CLEVIS, 10-32, LONG

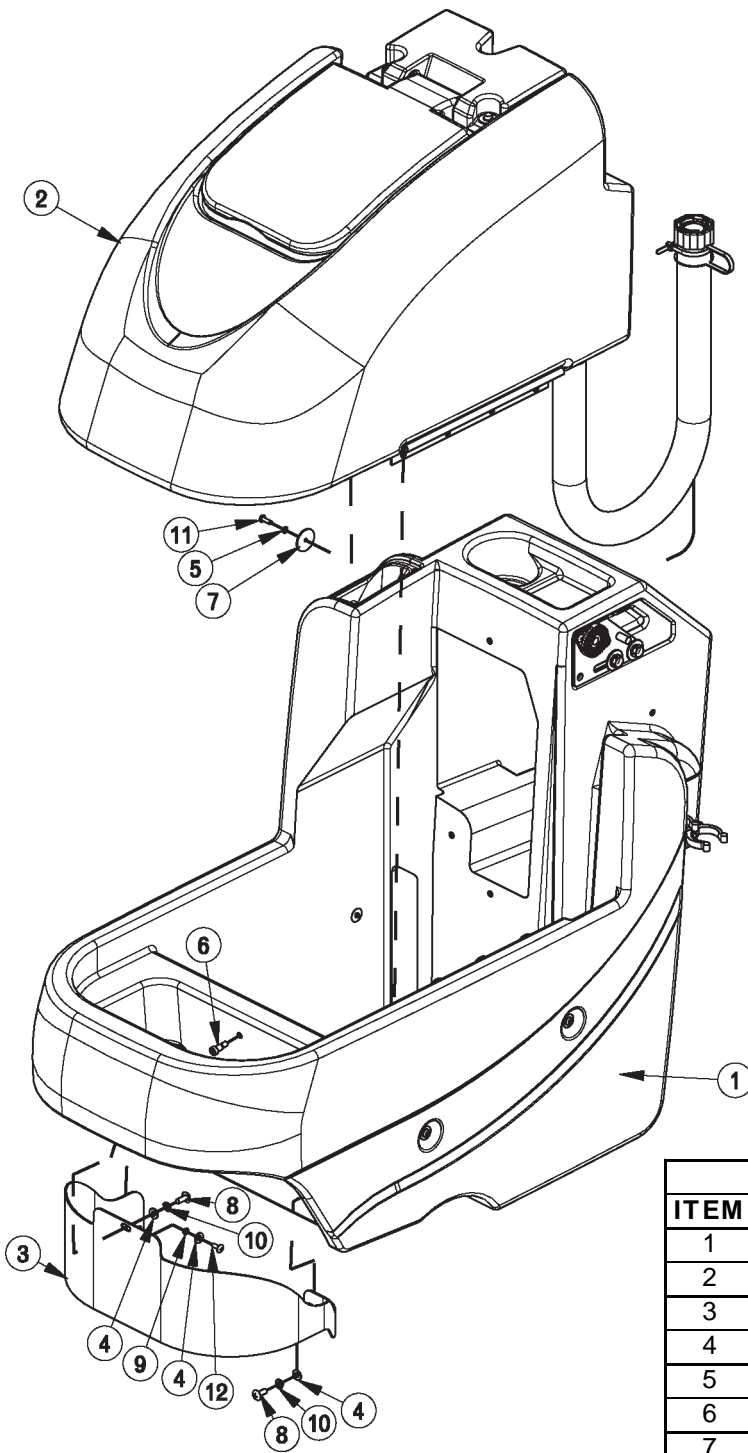

BILL OF MATERIAL - 172001BASE

ITEM	PART NO.	REQ'D	DESCRIPTION
1	172013	1	SOL TANK ASSY
2	172014	1	REC TANK ASSY
3	172144	1	PANEL, FRONT
4	711504	3	WSR-FLAT 1/4 ID SS
5	711543	4	WSR-HELICAL #10
6	712041	1	BLT- SHLDR 1/4-20 X .44 X .37
7	712312	4	WSR-FLAT .187 X 1.25
8	712565	2	SCR-MC 1/4-20X.63 SS TR HD
9	712757	1	WSR - HELICAL #10 SS
10	712758	2	WSR-HELICAL 1/4 SS
11	712812	4	SCR-MC 10-24 X .62 PPH ST PL
12	712822	1	SCR-MC TR HD 10-24 X .50 SS

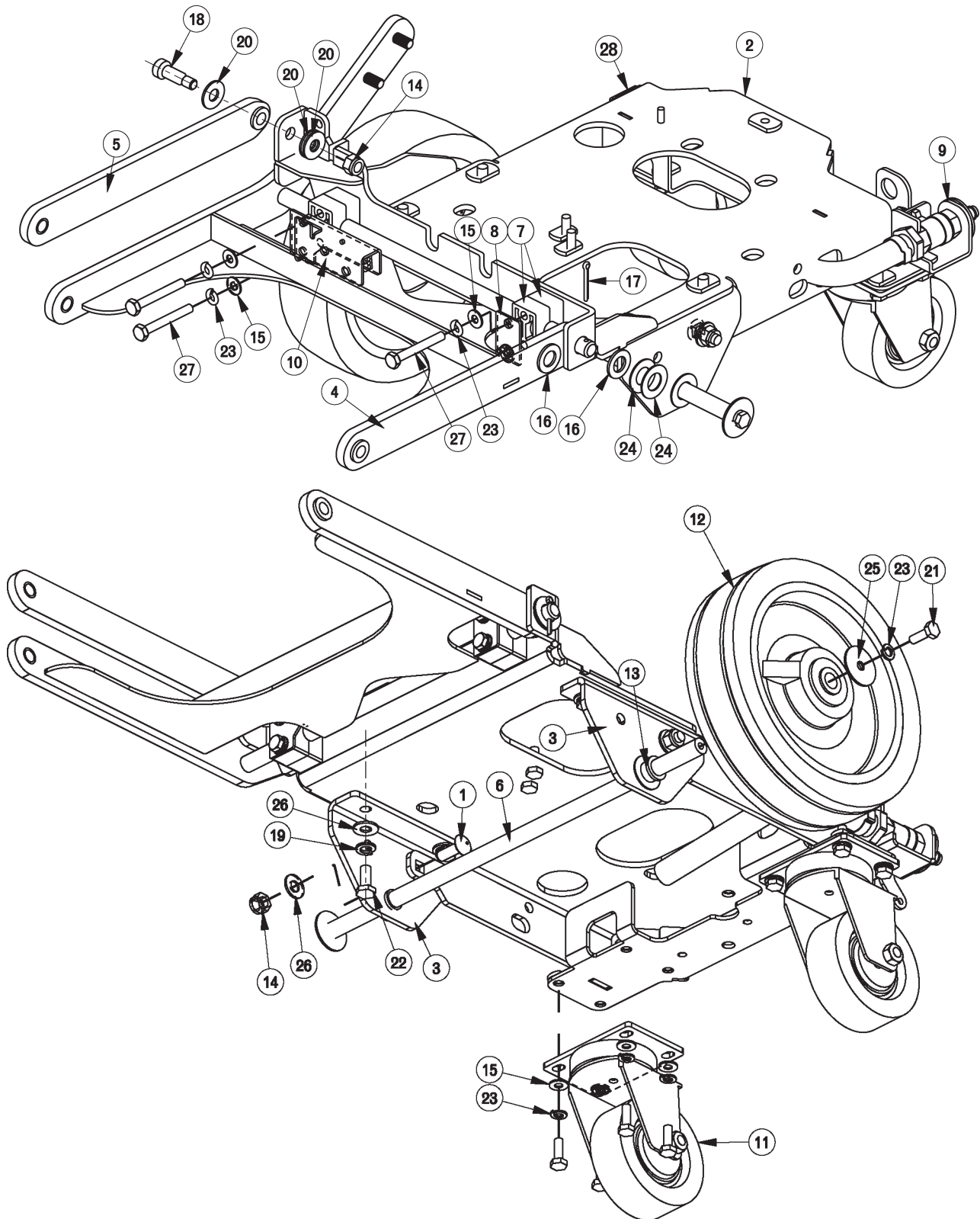

BILL OF MATERIAL - 172002 / 172002-1			
ITEM	PART NO.	REQ'D	DESCRIPTION
1	70-516-16	2	BLT-CAR 5/16-18 X 1.00
2	172020	1	MAIN FRAME WMNT
3	172024	2	WHEEL BRACKET
4	172025	1	DECK LIFT ASSY
5	172030	1	BAR, UPPER DECK LIFT W/ BUSH
6	172035	1	WHEEL ROD
7	172038	4	BEARING BLOCK
8	172039	1	BEARING BLOCK PLATE
9	172064	1	SOLUTION VALVE ASSY
10	172110	1	DECK SWITCH ASSY
11	172167	2	CASTER, 3-1/2 POLYURETHANE
12	172265	2	WHEEL, 8 X 2 X .5, 75A
13	260041	2	OILITE FLANGE BUSHING
14	711374	3	NUT-NYLOC 5/16-18
15	711504	12	WSR-FLAT 1/4 ID SS
16	711592	2	WSR-FLAT .50 X .9 X .075 NYL
17	711809	1	COTTER PIN, 1/8 X 1.0
18	712081	1	SHOULDER BLT 5/16-18 X 3/8 X .75
19	712140	4	WSR-HELICAL 5/16 SS
20	712301	3	WSR-FLAT .37 X .87 X .06
21	712562	12	BOLT-HH 1/4-20X3/4 SS
22	712575	4	BLT-HH 5/16-18 X .75 SS
23	712758	14	WSR-HELICAL 1/4 SS
24	712760	4	WSR-FLAT .56X1.06X.04 SS
25	712761	2	WSR-FLAT .28 X 1.25 X .059SS
26	712772	6	WSR-FLAT .344 x .75 x .06 SS
27	713007	4	BLT-HH 1/4-20 X 2 #5
28	809444	1	CLIP-CORD

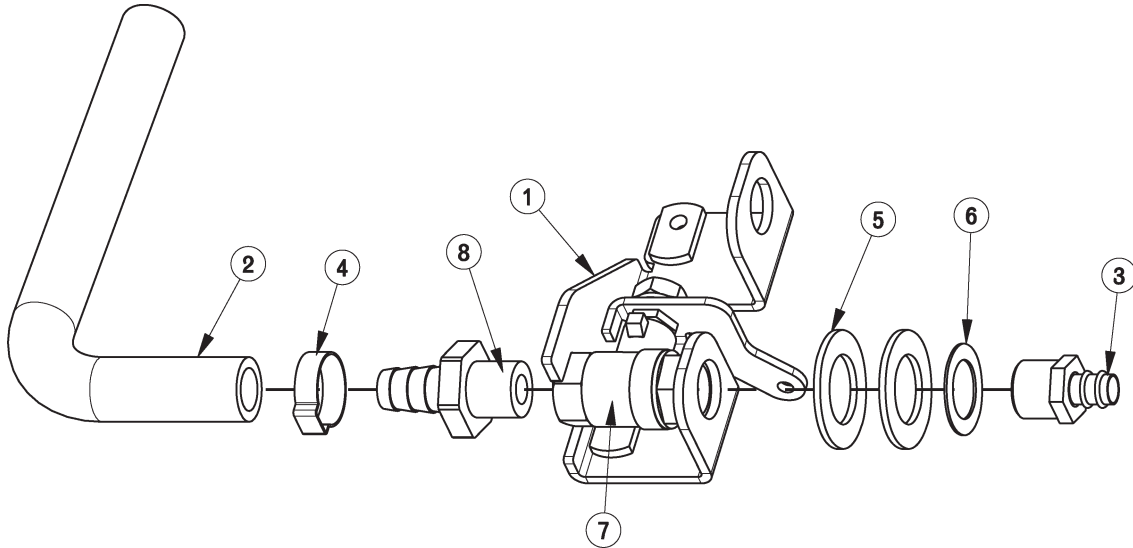

BILL OF MATERIAL - 172064			
ITEM	PART NO.	REQ'D	DESCRIPTION
1	172063	1	BKT, SOL VALVE MOUNT
2	172158	1	HOSE, 1/2"ID X 7.5" NYLOBRAID
3	320265	1	FITTING DUBL 3/8HBx3/8MPT
4	383347	1	CRIMP CLAMP 1/2 HOSE SS 185R
5	711512	2	WSR-FLAT .75X1.37X.08
6	711513	1	WSR-FLAT .69 X 1.06 X .03 SS
7	809415	1	VALVE, 3/8 FPT, 45 OPEN/CLOSE
8	827008	1	FITTING, 3/8 MPT 1/2 HOSE

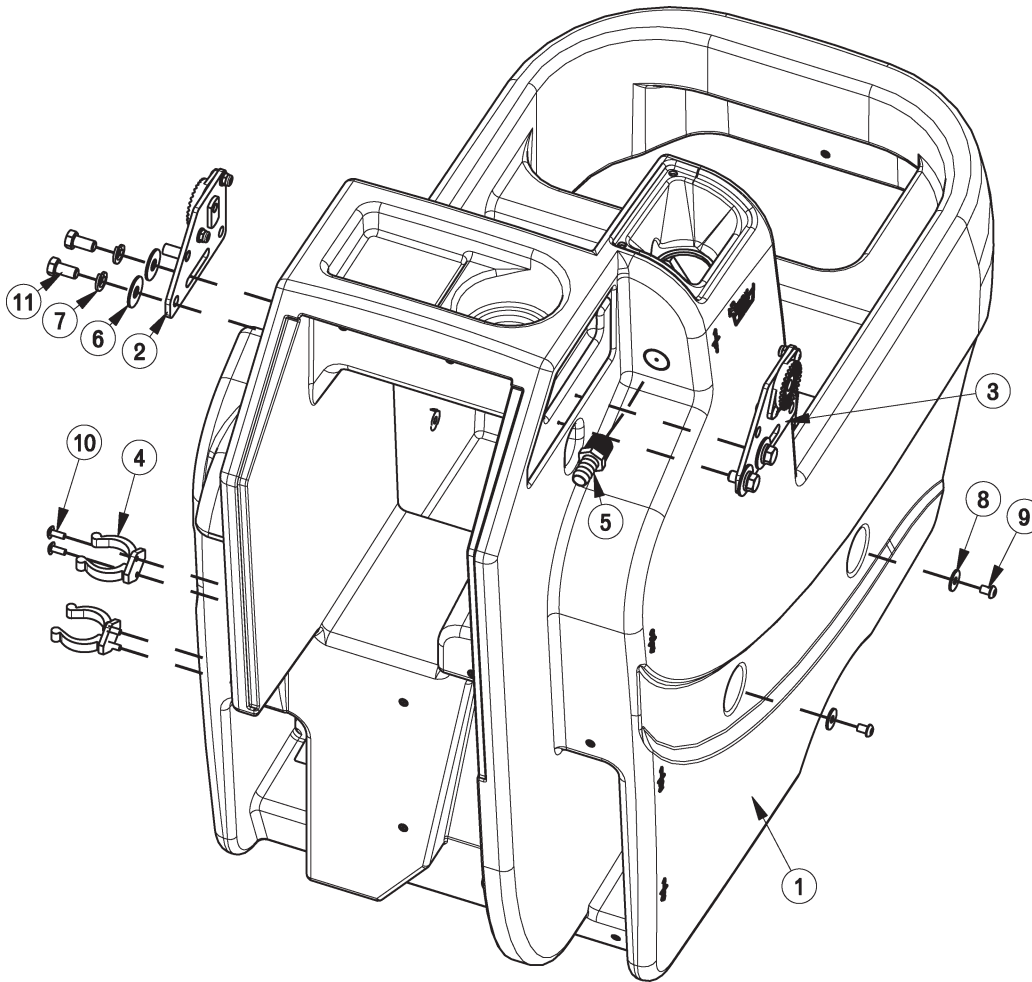

BILL OF MATERIAL - 172013

ITEM	PART NO.	REQ'D	DESCRIPTION
1	172003	1	SOLUTION TANK
2	172080	1	HANDLE MOUNT ASSY, LEFT
3	172082	1	HANDLE MOUNT ASSY, RIGHT
4	260579	2	TOOL CLIP, 1.5" HOSE
5	342438	1	FITTING, 1/2 MPT 1/2 HB BRASS
6	711507	4	WSR-FLAT .37 X 1.12 X .06
7	711546	4	WSR-HELICAL 3/8
8	711550	4	WSR NYLON .25 ID X .75 OD
9	712146	4	SCR-SC BHCS 1/4-20 X .37 SS
10	712822	4	SCR-MC TR HD 10-24 X .50 SS
11	713041	4	BLT-HH 3/8-16 X 3/4 #5

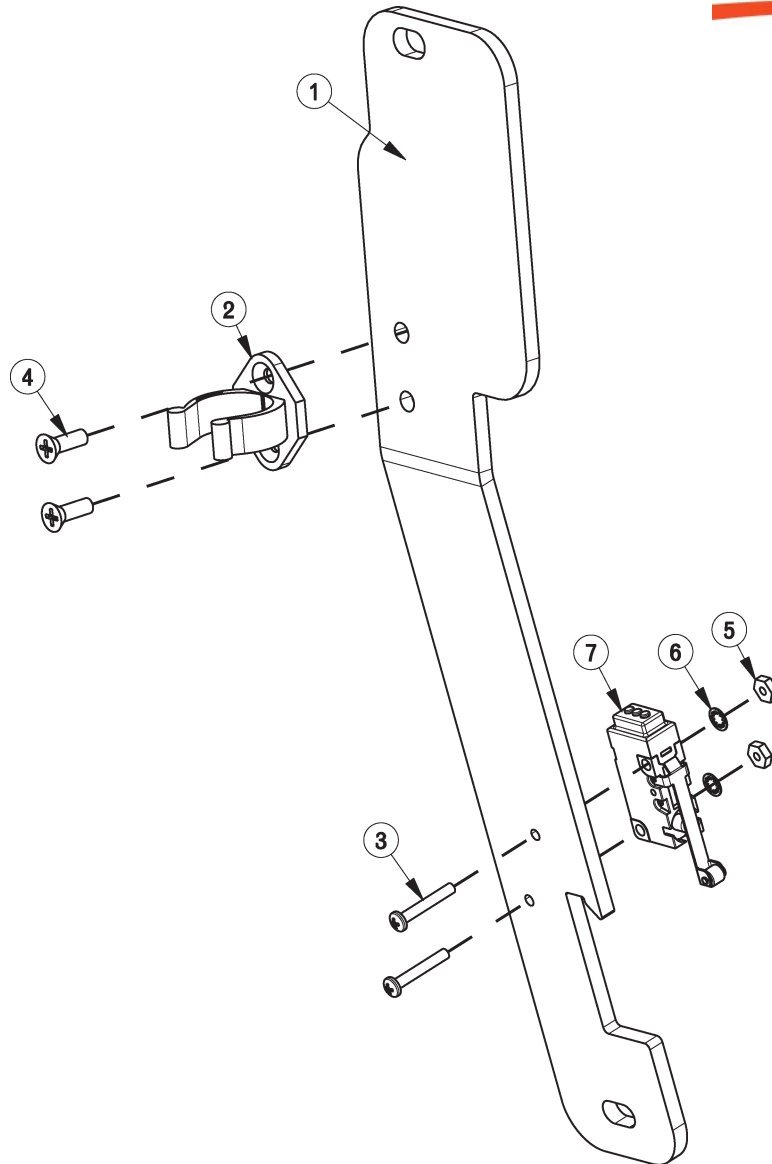

BILL OF MATERIAL - 172157			
ITEM	PART NO.	REQ'D	DESCRIPTION
1	172036	1	BKT, PEDAL STOP
2	172065	1	CLIP, FOR 1/2" ID HOSE
3	710493	2	SCR-MC 4-40 X .75 PAN HD
4	710530	2	SCR-MC FL HD 8-32 X .50 BRS
5	711428	2	NUT-HEX 4-40
6	712326	2	WSR-INT LOCK #4
7	747603-2	1	SWITCH ASY, MICRO ROLLER W/PACK/CONDUIT

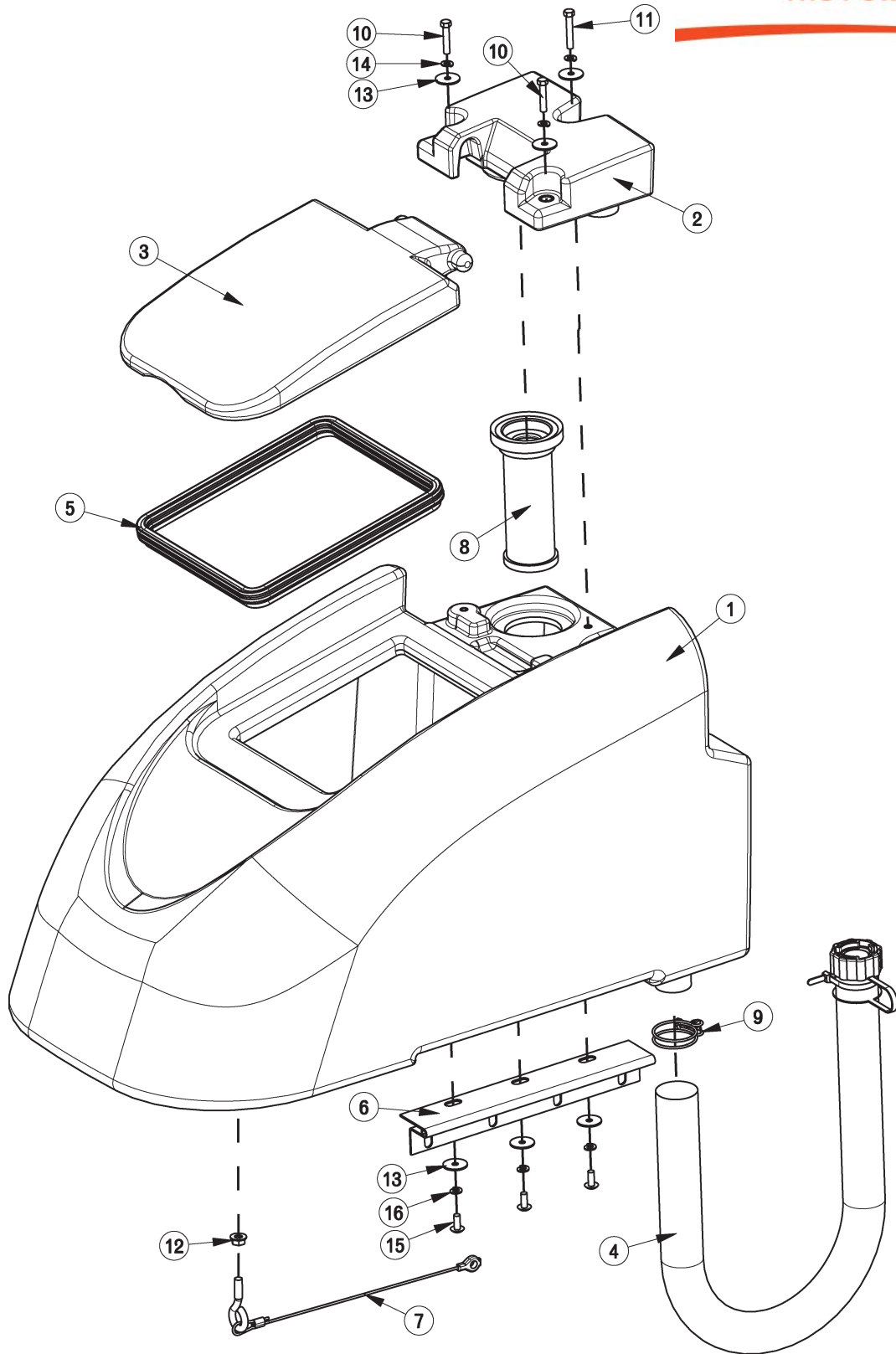



BILL OF MATERIAL - 172014			
ITEM	PART NO.	REQ'D	DESCRIPTION
1	172004	1	RECOVERY TANK
2	172005	1	VACUUM MANIFOLD
3	172007	1	LID
4	172011	1	HOSE, PINCH-OFF W/ CAP, 36"
5	172017	1	GASKET, LID
6	172049	1	HINGE, RECOVERY TANK
7	172067	1	REC TANK CABLE ASSY 11.625
8	172132	1	SCREENED FLOAT
9	260203	1	WIRE GRIP HOSE CLAMP
10	711210	2	BLT-HH 1/4-20 X 1.25 STPL
11	711212	1	BLT-HH 1/4-20 X 1.50 STPL
12	711379	1	NUT, FLANGED WIZZ 5/16-18
13	711519	6	WSR- FLAT .25 X 1.01 X .06
14	711544	3	WSR-HELICAL 1/4
15	712565	3	SCR-MC 1/4-20X.63 SS TR HD
16	712758	3	WSR-HELICAL 1/4 SS

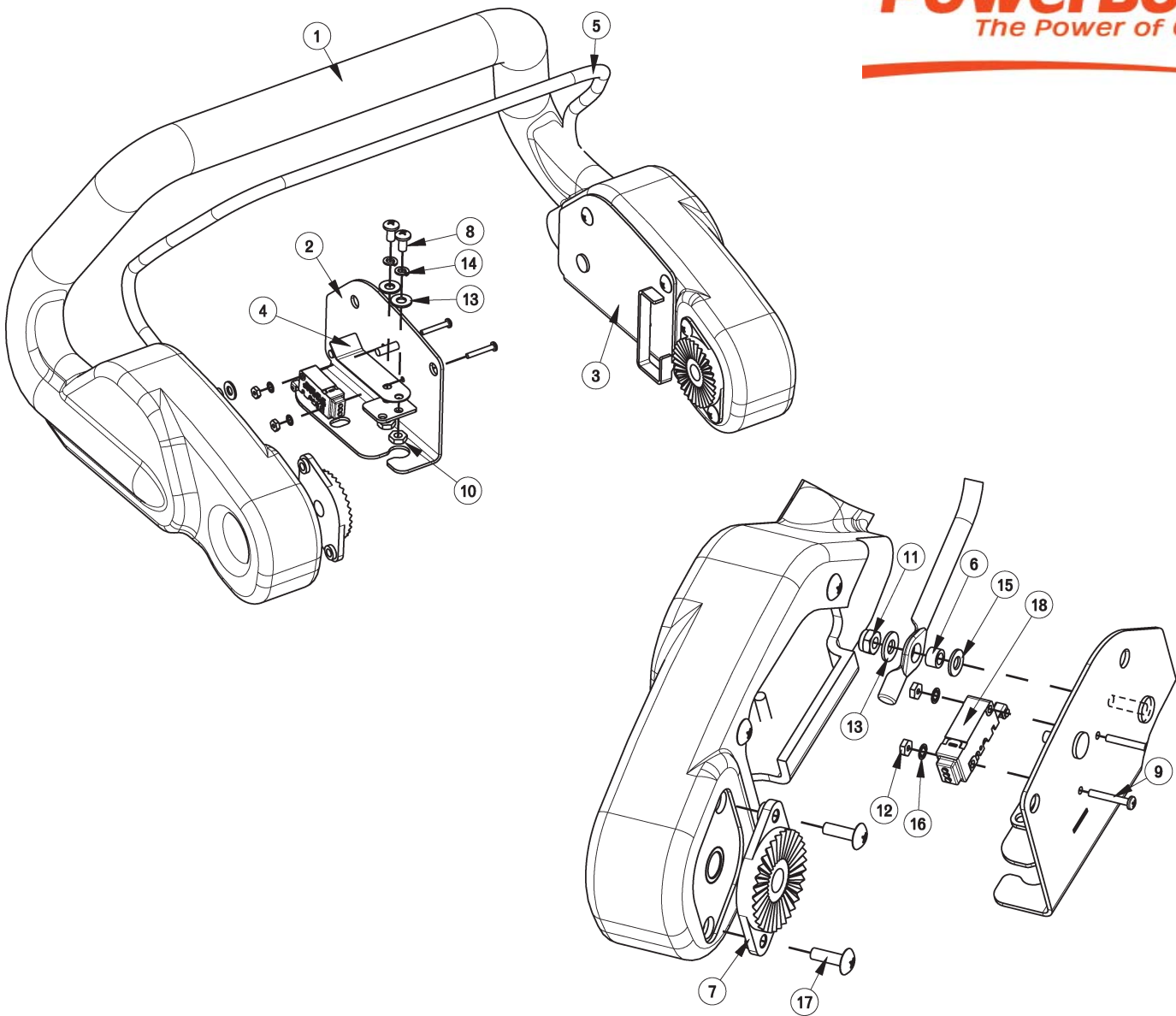

BILL OF MATERIAL - 172016			
ITEM	PART NO.	REQ'D	DESCRIPTION
1	172006	1	HANDLE
2	172053	1	BAIL PLATE WMT RH
3	172054	1	BAIL PLATE WMT LH
4	172057	2	LEAF SPRING
5	172059	1	BAIL, HANDLE
6	172074	2	SPACER, 5/16OD X 17GA, ALUM
7	270143	2	HANDLE PIVOT JAW
8	710353	4	SCR-MC RD HD 10-32 X .37 STL
9	710493	2	SCR-MC 4-40 X .75 PAN HD
10	711310	4	NUT, HEX 10-32 ST PL
11	711350	2	NUT-NYLOC 10-32
12	711428	2	NUT-HEX 4-40
13	711503	6	WSR, FLAT#10
14	711543	4	WSR-HELICAL #10
15	712320	2	WSR-NYLON .22 X .45 X .04
16	712326	2	WSR-INT LOCK #4
17	712830	10	SCR-MC 10-24 X .62 STLZ TR HD
18	747603-1	1	SWITCH ASY, MICRO ROLLER W/PACK/CONDUIT
19	747632	1	CABLE ASY, 5 COND 18G CONSOLE

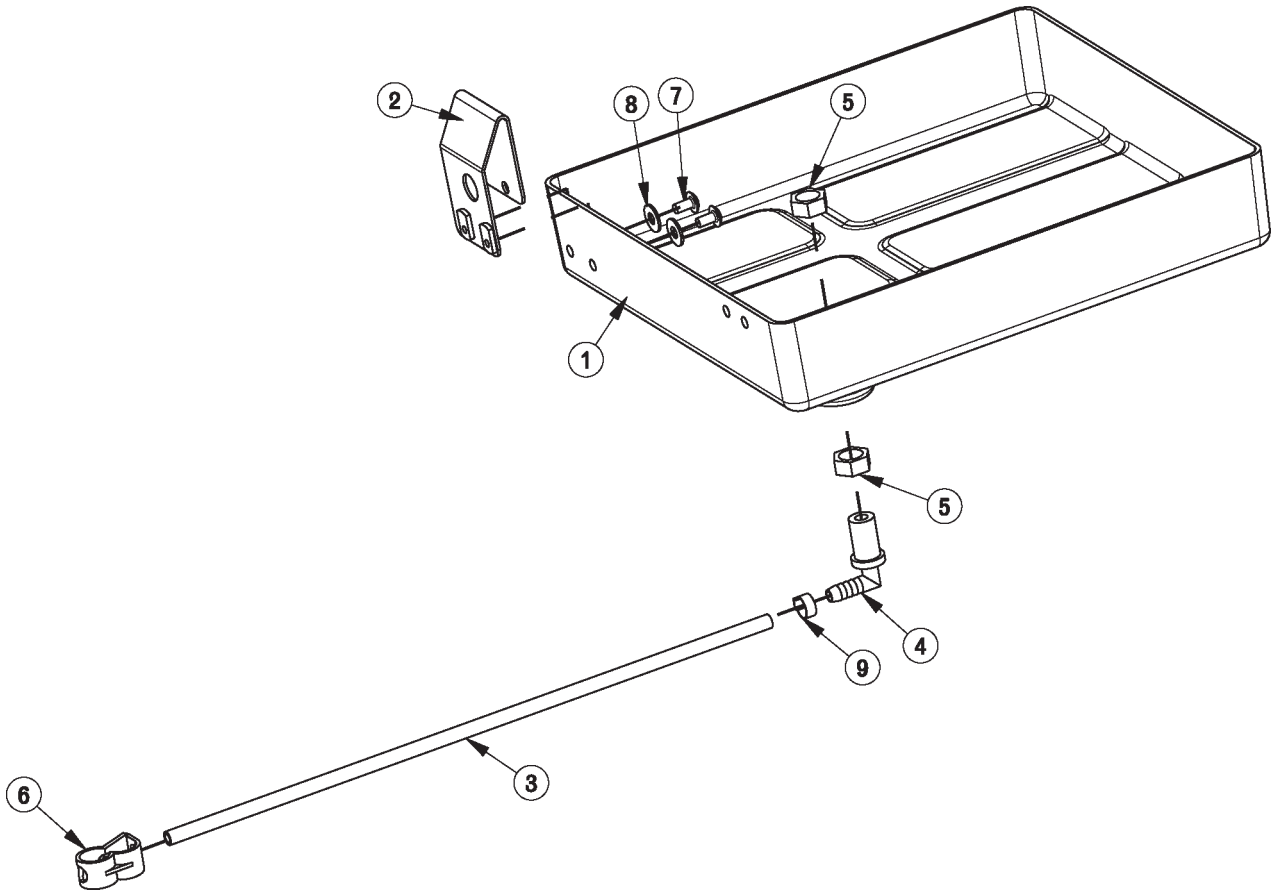

BILL OF MATERIAL - 172012			
ITEM	PART NO.	REQ'D	DESCRIPTION
1	172116	1	BATTERY BOX
2	172213	1	BKT, SPACER FOR BATTERIES
3	260224	1	18" HOSE
4	320271	1	NOZZLE BODY-ELBOW
5	320272	2	NOZZLE BODY LOCKNUT
6	320273	1	HOSE SHUT-OFF CLAMP
7	710178	2	SCR-MC 1/4-20 X .50 TRUSS STPL
8	711575	2	WSR-FLT .31x.75x.06ST
9	828490	1	CRIMP CLAMP 140R

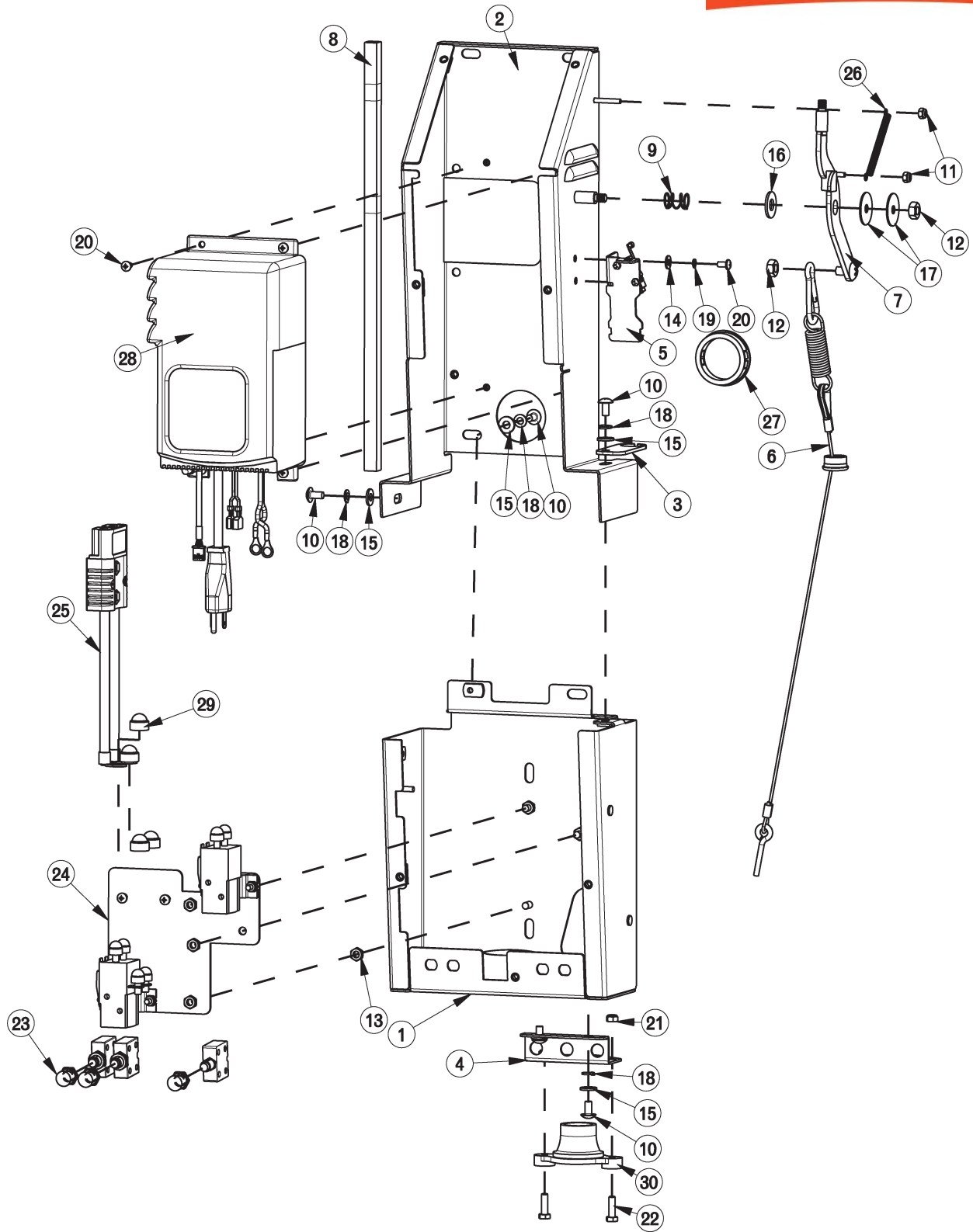



BILL OF MATERIAL - 172070-120			
ITEM	PART NO.	REQ'D	DESCRIPTION
1	172077	1	ELEC BOX-BOT HALF WMT
2	172088	1	ELEC BOX-TOP HALF WMT
3	172107	1	BKT, UPPER BUSHING MOUNT
4	172128	1	BKT, LOWER BUSHING MOUNT
5	172141	1	VAC SWITCH ASSY
6	172149	1	CABLE ASSY, SQUEEGEE LIFT
7	172152	1	VAC LEVER WMT
8	172188	1	FOAM TAPE, 1/2" SQ X 16.5"
9	670093	1	SPRING, COMPRESSION
10	710178	5	SCR-MC 1/4-20 X .50 TRUSS STPL
11	711372	2	NUT-NYLOC 8-32 STL ZINC
12	711383	2	NUT-HEX CLR LOC 5/16-18
13	711429	6	NUT-HEX 1/4-28 JAM STL Z
14	711503	2	WSR, FLAT#10
15	711505	5	WSR-FLAT 1/4
16	711508	1	WSR-FLAT .44X 1.0X.08
17	711516	2	WSR- FLAT .31 X 1.25 X .05
18	711544	5	WSR-HELICAL 1/4
19	712757	2	WSR - HELICAL #10 SS
20	712810	6	SCR-MC 10-24 X .37 ST PL
21	717018	2	NUT-NYLOC M6 X 1.0
22	717022	2	BOLT-HH M6X1.0 X 20
23	742748	3	CIRCUIT BREAKER BOOT
24	747630	1	ELEC PANEL ASSY
25	747637	1	WIRE ASY, MACHINE-BATTERY
26	762084	1	SPRING-EXT
27	762400	1	HEYCO BUSHING 2.00"
28	957745	1	CHARGER,24VDC 12A ON-BOARD 120VAC
29	15592033	2	CAP, SAFETY NUT COVER M8
30	90508391	1	BUSHING, CABLE GUIDE, HAKO

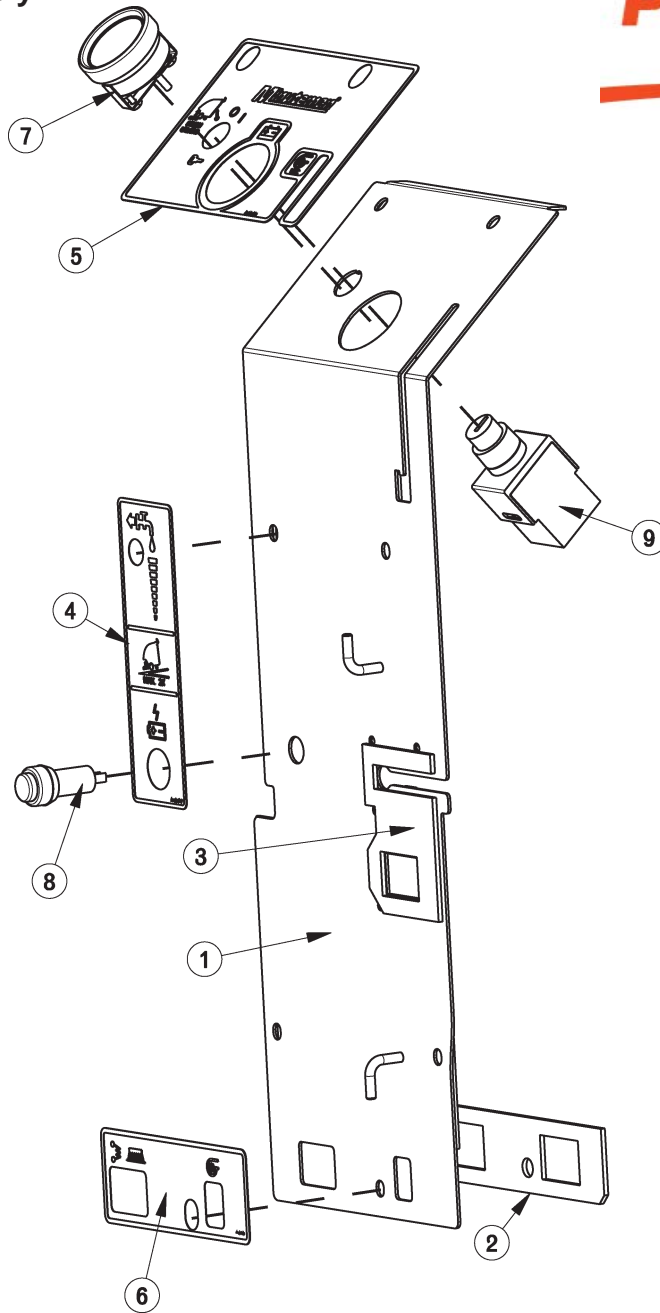

BILL OF MATERIAL - 172073			
ITEM	PART NO.	REQ'D	DESCRIPTION
1	172181	1	ELEC BOX, COVER, WMT
2	172193	1	GASKET, CB OUTLINE
3	172194	1	GASKET, CHARGER CORD PLATE
4	715672	1	DECAL, BD ELEC BOX
5	715673	1	DECAL, BD DASHBOARD
6	715675	1	DECAL, BD CIRC BKRS
7	740216	1	VOLT METER
8	747614	1	CHARGE STATUS INDICATOR
9	747617-1	1	KEYSWITCH ASY, KEYSWITCH + WIR

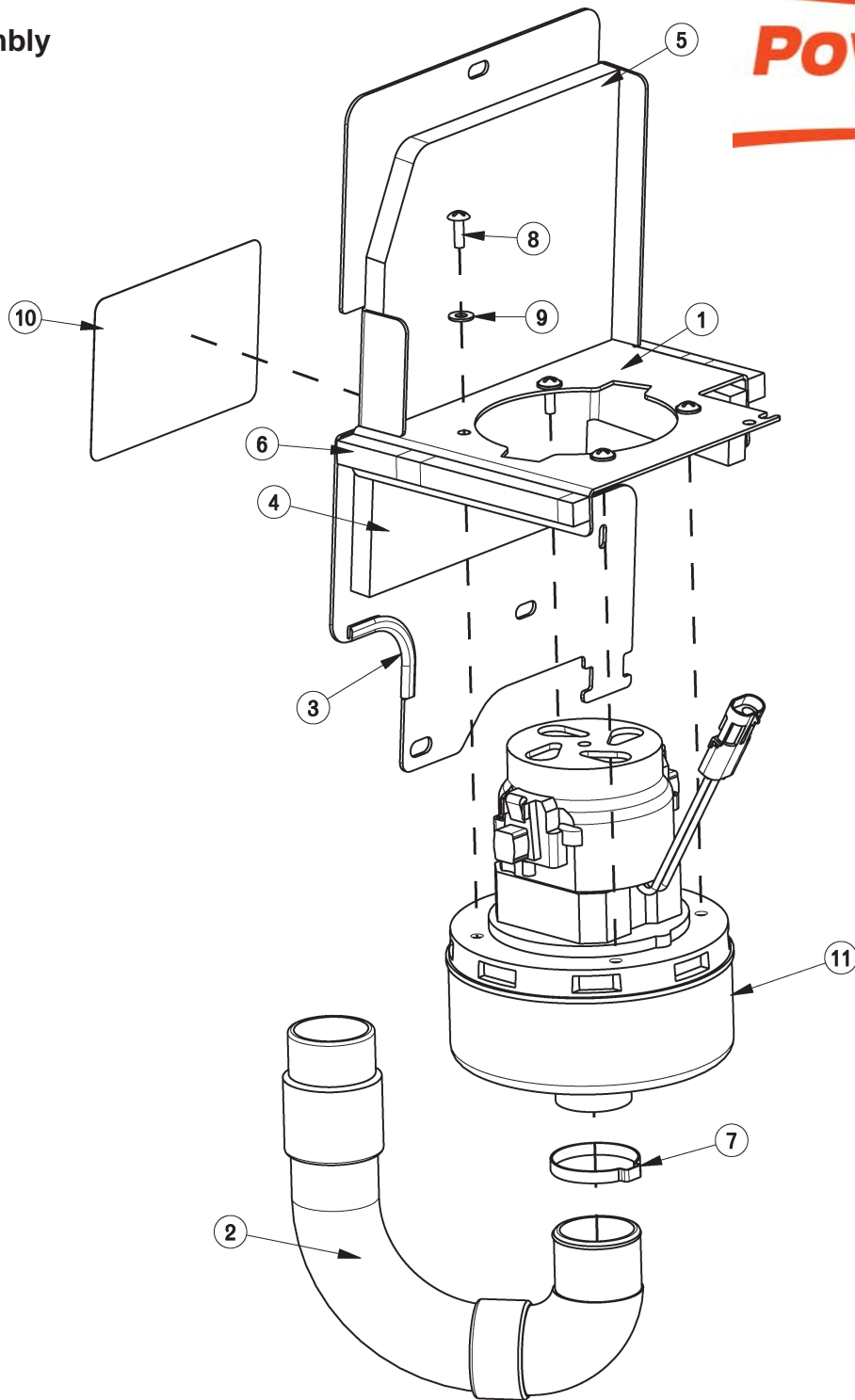

BILL OF MATERIAL - 172050

ITEM	PART NO.	REQ'D	DESCRIPTION	ITEM	PART NO.	REQ'D	DESCRIPTION
1	172045	1	VAC MOUNT WMT	7	450095	1	CRIMP CLAMP, 1.75"
2	172048	1	HOSE, STRETCH 13"	8	711160	4	#10 X 5/8 HI-LO
3	172124	1	EDGE TRIM, .063 X 3.0, BLACK	9	711503	4	WSR, FLAT#10
4	172186	1	FOAM COVER, FRONT 1	10	715676	1	DECAL, BATT CABLE ROUTE
5	172187	1	FOAM COVER, FRONT 2	11	747607-1	1	VAC MOTOR ASY
6	172188	2	FOAM TAPE, 1/2" SQ X 16.5"				

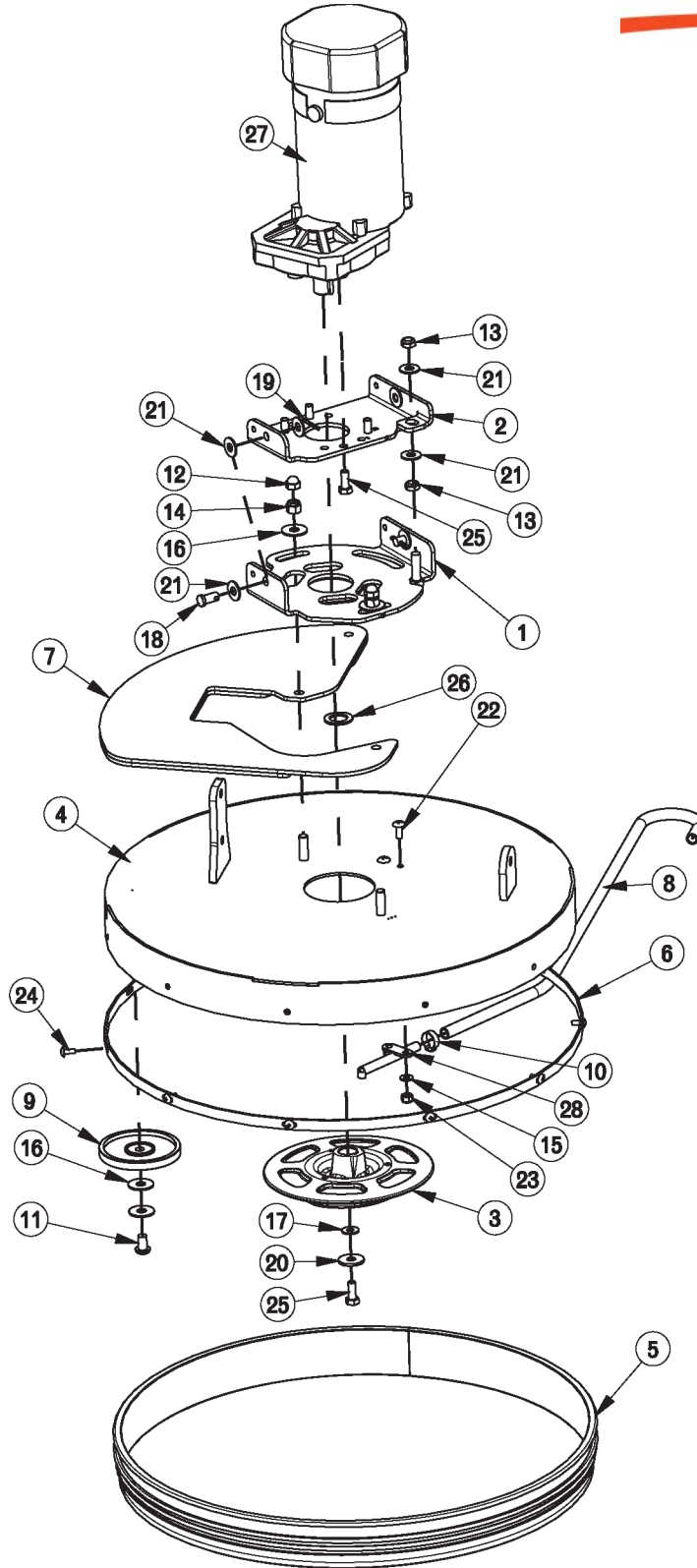

BILL OF MATERIAL - 172100			
ITEM	PART NO.	REQ'D	DESCRIPTION
1	172040	1	DECK ANGLE ADJUST WMT
2	172044	1	PLATE, MOTOR MOUNT
3	172095	1	BRUSH HUB ASSY
4	172101	1	DECK COVER WMT 20"
5	172121	1	20" DECK SKIRT
6	172125	1	RETAINER, 20" DECK SKIRT
7	172208	1	E20 BRUSH DECK PLATE
8	172216	1	HOSE-WIRE REINF 3/8 X 29"
9	210153	1	ROLLER WHEEL
10	450076	1	CLAMP-CRIMP 185R SS
11	710985	1	SCR-SC 3/8-16 X .62 ST PL
12	711354	2	NUT-ACORN 3/8-16 ST NI
13	711375	2	NUT-NYLOC 3/8-16 X 1/2 NUT
14	711380	2	NUT-NYLOC 3/8-16 NUT
15	711504	2	WSR-FLAT 1/4 ID SS
16	711507	4	WSR-FLAT .37 X 1.12 X .06
17	711575	1	WSR-FLT .31x.75x.06ST
18	711679	2	CLEVIS PIN 3/8 X 3/4
19	711809	2	COTTER PIN, 1/8 X 1.0
20	711855	1	WSR-FLT .37X1.12X.10 STL Z HARD
21	712301	8	WSR-FLAT .37 X .87 X .06
22	712565	2	SCR-MC 1/4-20X.63 SS TR HD
23	712667	2	NUT, HEX 1/4-20 NYLOC SS
24	712822	11	SCR-MC TR HD 10-24 X .50 SS
25	717024	5	BOLT-HH M8X1.25 X 20
26	717025	1	WSR-FLAT 13/16ID X 1.25 X .08
27	747600	1	MOTOR, OFFSET PM GEAR, 550W
28	90311663	1	HAKO SOL FEED NOZZLE

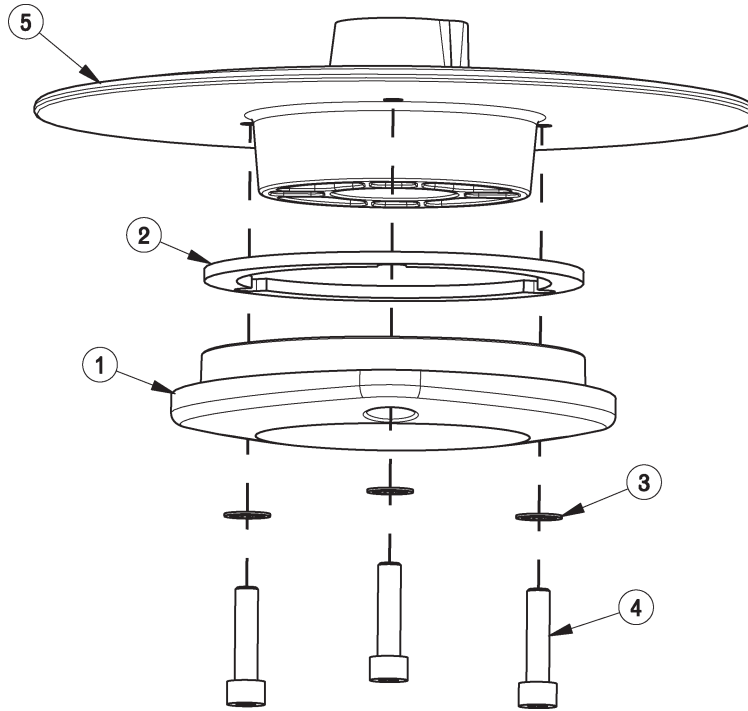

BILL OF MATERIAL - 172095			
ITEM	PART NO.	REQ'D	DESCRIPTION
1	172097	1	BRUSH HUB BASE
2	172133	1	BRUSH HUB SPACER
3	711554	3	WSR-INTERNAL LOCK 1/4 ID
4	717026	3	SCR-SC SHCS M6X1.0 X 25 STL Z
5	172096MCH	1	BASE, DRIVE HUB WITH KEYWAY

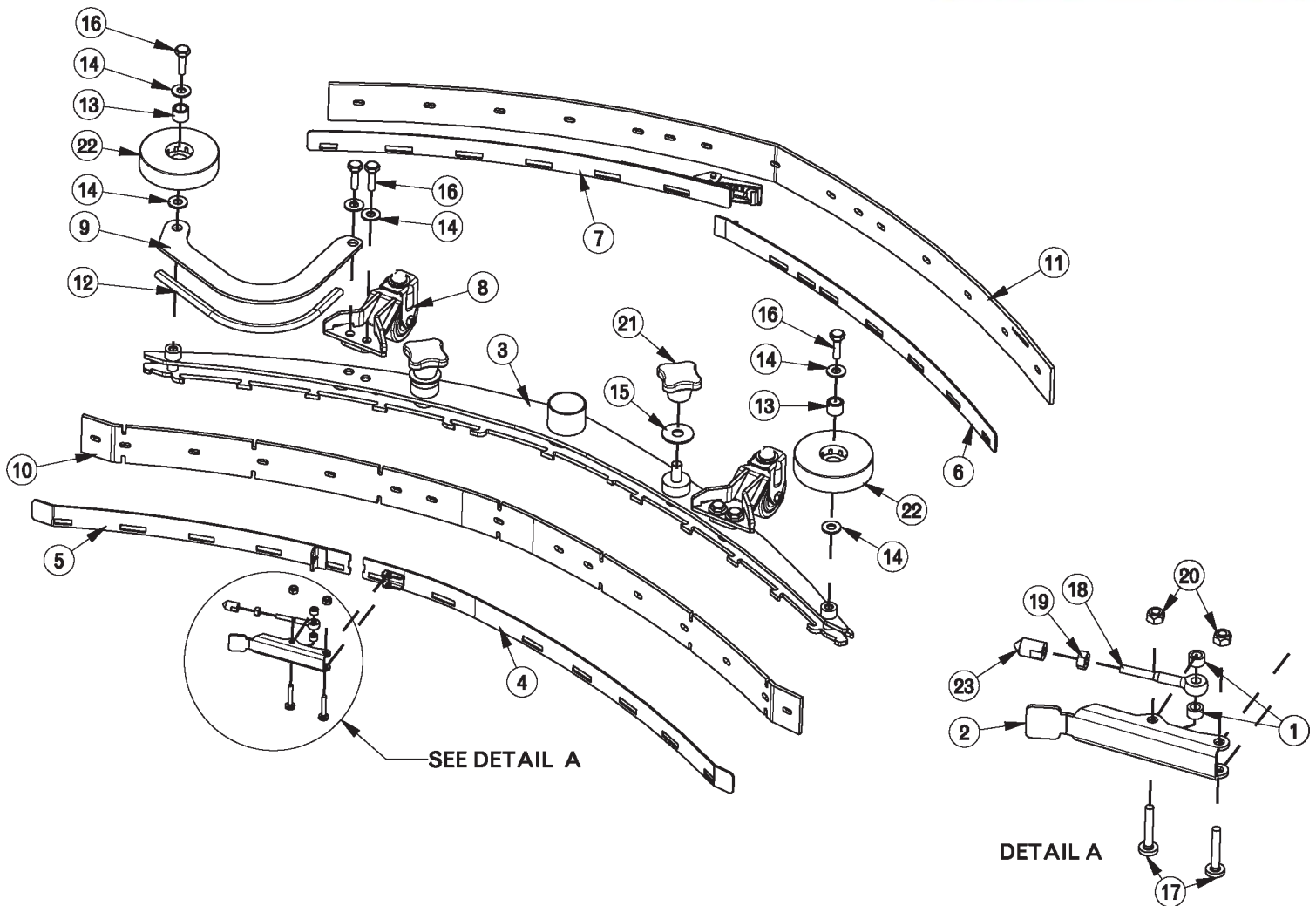

BILL OF MATERIAL - 172270

ITEM	PART NO.	REQ'D	DESCRIPTION	ITEM	PART NO.	REQ'D	DESCRIPTION
1	172074	2	SPACER, 5/16OD X 17GA, ALUM	12	172274	1	EDGE TRIM 5/16 X 10" BLACK
2	172234	1	LEVER, 90535758	13	430322	2	BUSHING .435 X .625 X .50
3	172235	1	SQUEEGEE WMT, 34" (860)	14	712772	8	WSR-FLAT .344 x .75 x .06 SS
4	172240	1	STRAP WMT, FRONT LEFT	15	712773	2	WSR FLAT .438 X 1.25 X .07 SS
5	172241	1	STRAP WMT, FRONT	16	11039567	6	BLT-HH M8 X 25 SS DIN933
6	172245	1	STRAP WMT, REAR	17	11175494	2	SCR-MC M5 X 25 SS DIN7985
7	172246	1	STRAP WMT, REAR	18	11518313	1	BLT-EYE M5 X 40 SS
8	172250	2	SQUEEGEE CASTER ASSY	19	12022430	1	NUT-HEX M5 SS DIN934
9	172271	1	BUMPER, 34" SQG	20	12040283	2	NUT-HEX M5 NYLOC SS DIN985
10	172272	1	FRNT SQG BLADE 34", 1/8 PU	21	17133026	2	KNOB, M10 STAR HANDLE
10A	172282	1	SQUEEGEE, FRONT BLADE 34", 1/8 LINATEX	22	90336637	2	WHEEL, 3.15OD
11	172273	1	REAR SQG BLADE 34", 1/8 PU	23	90513631	1	PIN, THD 90513631
11A	172283	1	SQUEEGEE, REAR BLADE 34", 1/8 LINATEX				

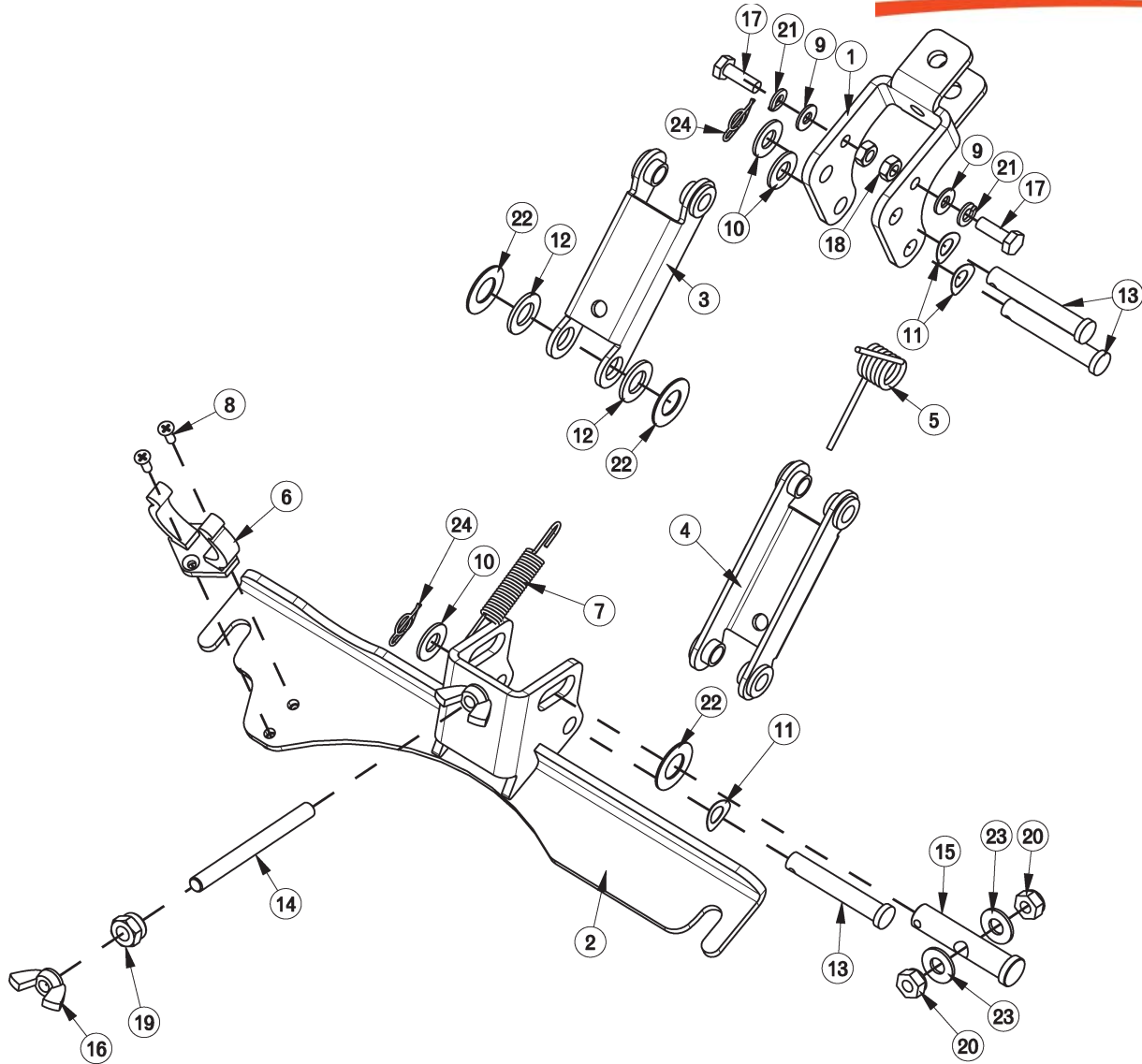

BILL OF MATERIAL - 172150							
ITEM	PART NO.	REQ'D	DESCRIPTION	ITEM	PART NO.	REQ'D	DESCRIPTION
1	172134	1	BKT, MAIN SQUEEGEE HINGE	13	711678	3	CLEVIS PIN 3/8 X 2-1/4
2	172155	1	SQUEEGEE MOUNT WMT	14	712147	1	ROD-THD 5/16-18 X 3.5 SS
3	172196	1	SQ TOP LINK W/ BUSHING	15	712148	1	CLEVIS PIN, 1/2 x 2.25 W/ HOLE
4	172197	1	SQ BOT LINK W/ BUSH	16	712157	2	NUT- WING 5/16-18 SS
5	172261	1	TORSION SPRING	17	712562	2	BOLT-HH 1/4-20X3/4 SS
6	260579	1	TOOL CLIP, 1.5" HOSE	18	712665	2	NUT-HEX 1/4-20 SS
7	430051	1	RETURN SPRING-3.00"	19	712680	1	NUT-HEX 5/16-18 SS
8	710530	2	SCR-MC FL HD 8-32 X .50 BRS	20	712683	2	NUT, HEX 5/16-18 NYLOC SS
9	711504	2	WSR-FLAT 1/4 ID SS	21	712758	2	WSR-HELICAL 1/4 SS
10	711515	3	WSR-FLAT .406 X .812 X .0625	22	712760	3	WSR-FLAT .56X1.06X.04 SS
11	711523	3	WSR-WAVE .37X .68 X .08	23	712772	2	WSR-FLAT .344 x .75 x .06 SS
12	711592	2	WSR-FLAT .50 X .9 X .075 NYL	24	3400125	2	PIN-COTTER 3/8 RUE RING

1 Wiring Diagrams

PAGE LAYOUT

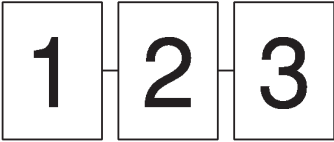

PAGES GO TOGETHER AS SHOWN TO SEE THE ENTIRE SCHEMATIC AS ONE.

ELECTRICAL BOX COVER ASSEMBLY 172073

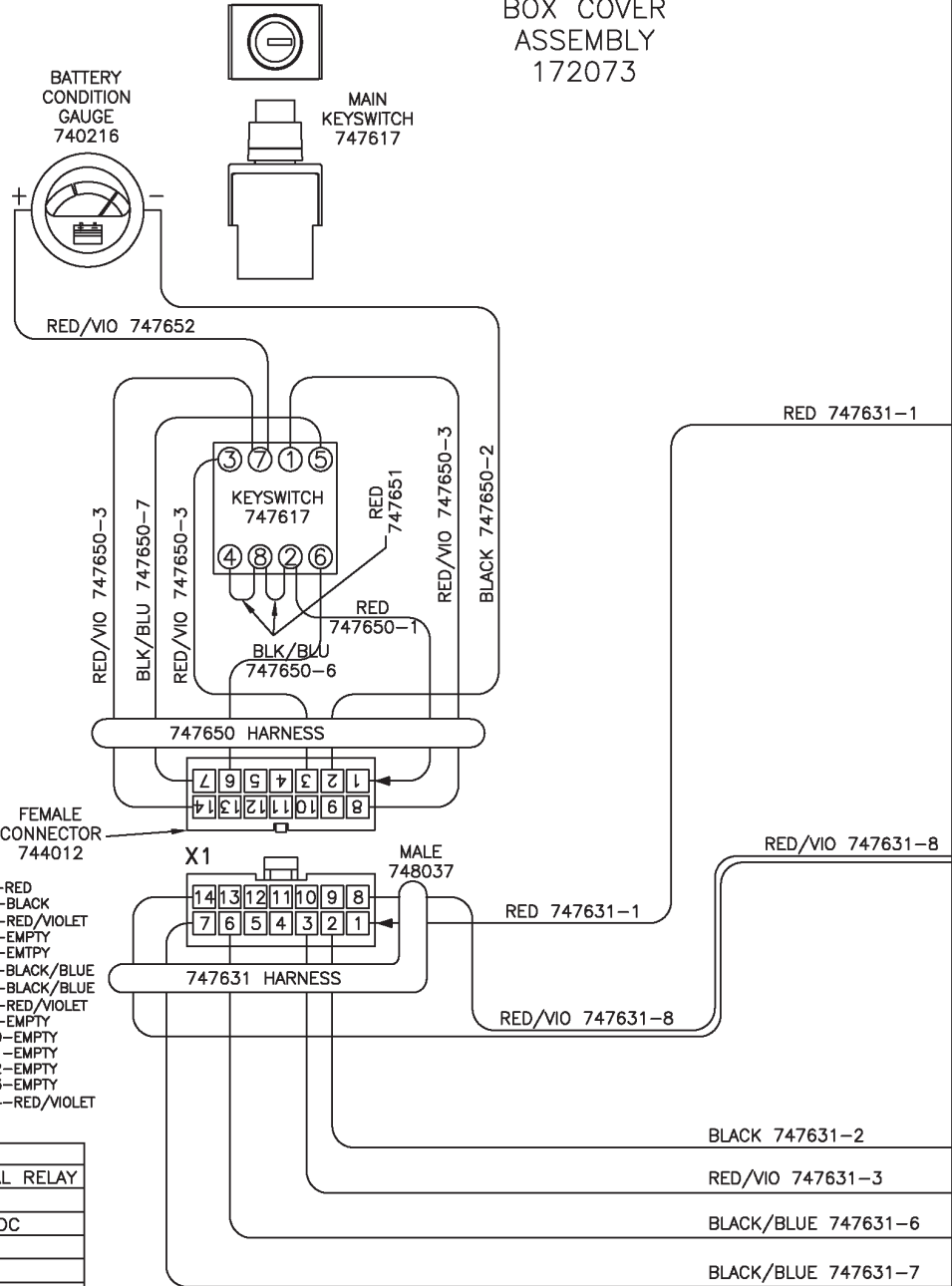

CONNECTOR NUMBERS AND NAMES

CONNECTOR #	DESCRIPTION
X1	KEYSWITCH
X2	OPERATOR HANDLE SWITCH
X3	CHARGER STATUS INDICATOR
X4	VACUUM SWITCH
X5	BATTERY CONNECTOR
X6	VACUUM MOTOR
X7	BRUSH MOTOR SWITCH
X8	BRUSH UNLOAD SWITCH
X9	OPTIONAL: SOLENOID SWITCH
X10	OPERATOR HANDLE CABLE
X11	OPERATOR HANDLE CABLE
X12	-
X13	-
X14	-
X15	ACCESSORY CONNECTION
X16	ACCESSORY CONNECTION
X17	OPTIONAL (747656 GREY/RED)
X18	OPTIONAL (747657 GREY/BLACK)

- 1-RED
- 2-BLACK
- 3-RED/VIOLET
- 4-EMPTY
- 5-EMPTY
- 6-BLACK/BLUE
- 7-BLACK/BLUE
- 8-RED/VIOLET
- 9-EMPTY
- 10-EMPTY
- 11-EMPTY
- 12-EMPTY
- 13-EMPTY
- 14-RED/VIOLET

X1: MAIN KEYSWITCH ASSEMBLY: 747617-1

PIN #	COLOR	WHERE TO/FROM
1	RED	X13: BATTERY CHARGER INTERNAL RELAY
2	BLACK	RELAY COILS: 0V
3	RED/VIOLET	BRUSH MOTOR RELAY COIL: 24VDC
4	EMPTY	-
5	EMPTY	-
6	BLACK/BLUE	BRUSH RELAY NORMALLY CLOSED
7	BLACK/BLUE	BRUSH UNLOAD SWITCH P:B
8	RED/VIOLET	X12: MAIN RELAY COIL: 24VDC
9	EMPTY	-
10	EMPTY	-
11	EMPTY	-
12	EMPTY	-
13	EMPTY	-
14	RED/VIOLET	X12: MAIN RELAY COIL: 24VDC

BATTERY CHARGER: 957745 or 957753

	COLOR	WHERE TO/FROM
X13	RED	X13: KEYSWITCH P:1
X14	BLACK	X14: CONTROL CB 4.0A
14GA	RED	MAIN RELAY + (REAR LEFT POST)
14GA	BLACK	MAIN RELAY - (FRONT LEFT POST)

OTHER WIRE COLORS

-	RED	BATTERY 24VDC: +
-	BLACK	BATTERY 0VDC: -
-	GREEN/YELLOW	GROUND
-	BLACK/BLUE	BRUSH UNLOAD CIRCUIT
-	RED/BLACK	BRUSH UNLOAD CIRCUIT: MICRO SWITCH
-	RED/VIOLET	24VDC AFTER MAIN KEYSWITCH
X15	GREY/RED	OPTIONAL POWER 24VDC: 3A MAX
X16	GREY/BLACK	OPTIONAL POWER 0VDC: 3A MAX

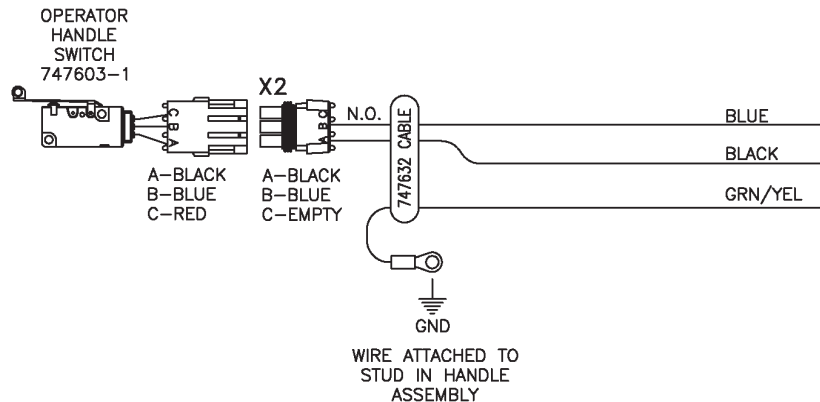

2

ELECTRICAL BOX
ASSEMBLY
172070-120
172070-230

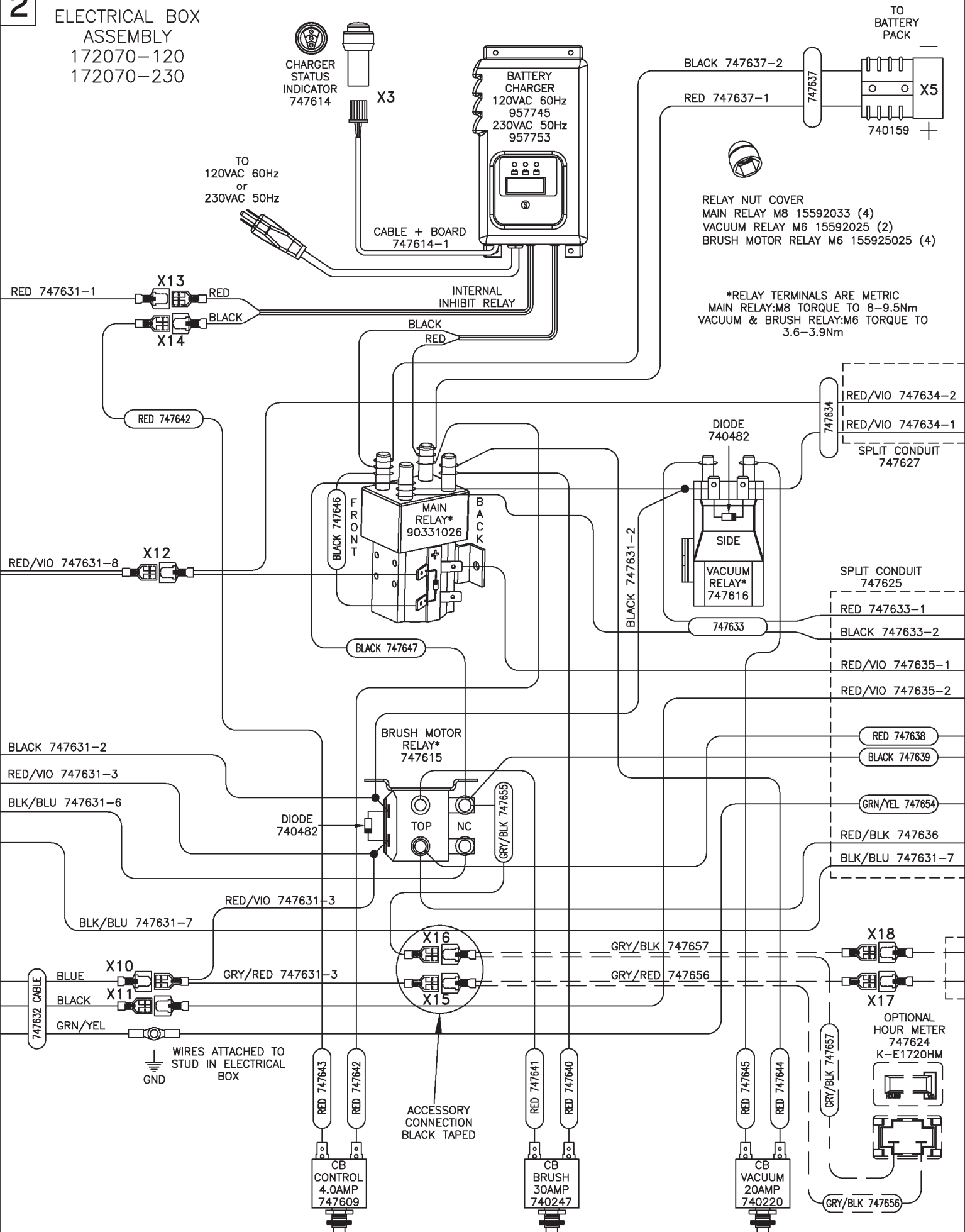

3

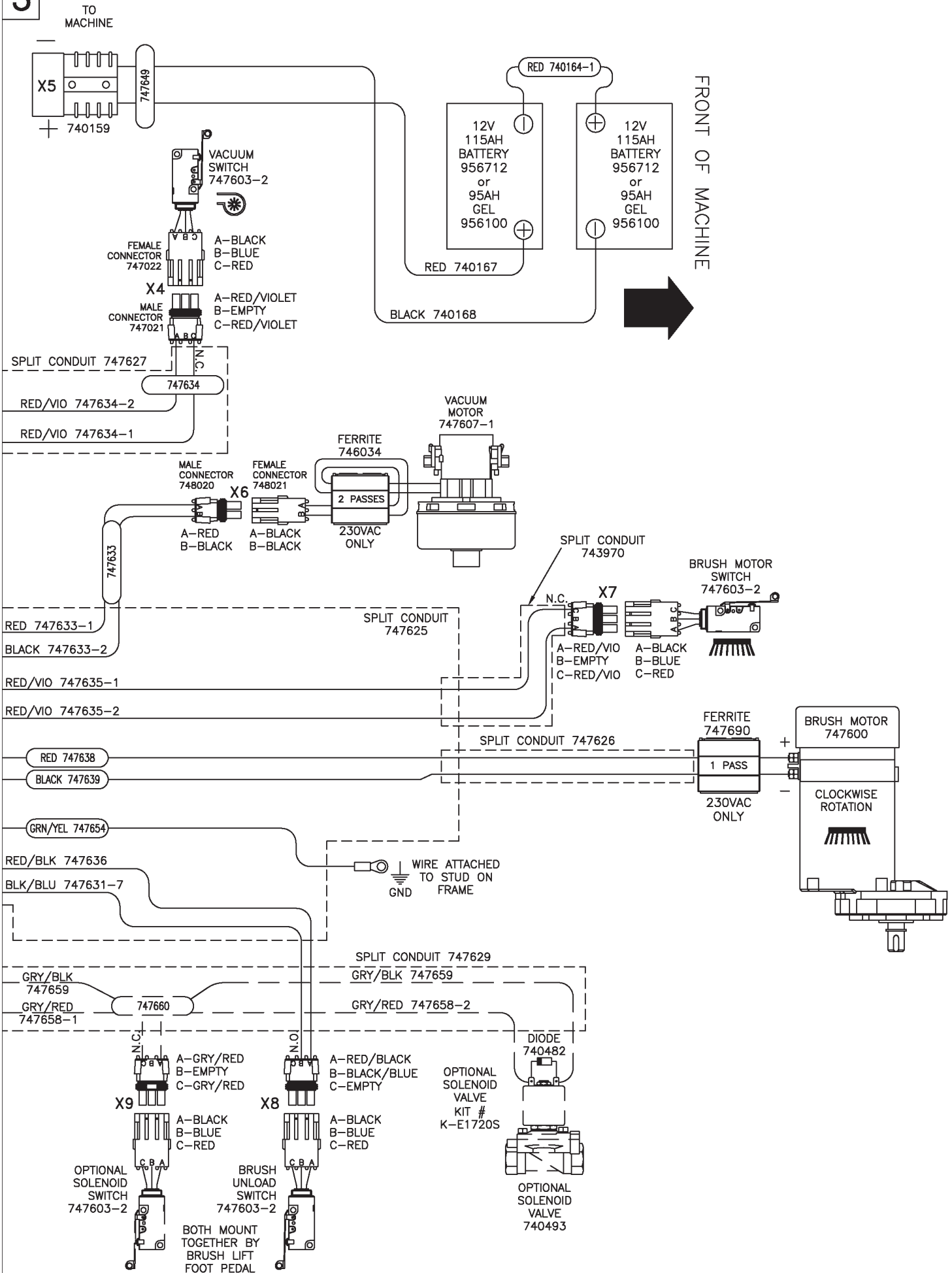

Revision F
Effective November 1, 2008
PowerBoss Made Simple Industrial Limited Warranty

Minuteman International owner of PowerBoss warrants to the original purchaser/user that the product is free from defects in workmanship and materials under normal use. PowerBoss will, at its option, repair or replace without charge, parts that fail under normal use and service when operated and maintained in accordance with the applicable operation and instruction manuals. All warranty claims must be submitted through and approved by factory authorized repair stations.

This warranty does not apply to normal wear, or to items whose life is dependent on their use and care. Parts not manufactured by PowerBoss are covered by and subject to the warranties and/or guarantees of their manufacturers. Please contact Minuteman International for procedures in warranty claims against these manufacture.

Special warning to purchaser – Use of replacement parts not manufactured by PowerBoss or its designated licensees, will void all warranties expressed or implied. A potential health hazard exists without original equipment replacement.

All warranted items become the sole property of Minuteman International or PowerBoss or its original manufacturer, whichever the case may be.

PowerBoss disclaims any implied warranty, including the warranty of merchantability and the warranty of fitness for a particular purpose. PowerBoss assumes no responsibility for any special, incidental or consequential damages.

This limited warranty is applicable only in the U.S.A. and Canada, and is extended only to the original user/purchaser of this product. Customers outside the U.S.A. and Canada should contact their local distributor for export warranty policies. PowerBoss is not responsible for costs or repairs performed by persons other than those specifically authorized by PowerBoss. This warranty does not apply to damage from transportation, alterations by unauthorized persons, misuse or abuse of the equipment, use of non-compatible chemicals, or damage to property, or loss of income due to malfunctions of the product. If a difficulty develops with this machine, you should contact the dealer from whom it was purchased.

This warranty gives you specific legal rights, and you may have other rights, which vary from state to state. Some states do not allow the exclusion or limitation of special, incidental or consequential damages, or limitations on how long an implied warranty lasts, so the above exclusions and limitations may not apply to you.

	Travel*	Labor	Parts	Engine	Extended Warranty	Costs
Walk behinds						
Battery sweepers	Ninety days	One year	One year	N/A	2 years Parts + Labor (or 2000 Hours)	2%
IC sweepers	Ninety days	One year	One year	Through manufacturer	2 years Parts + Labor (or 2000 Hours)	2%
Battery scrubbers	Ninety days	Two years	Three years	N/A	3 Years Parts + Labor (or 3000 Hours)	2%
Riders						
Battery scrubbers	Ninety days	Two years	Three years/2000 hrs	N/A	3 Years Parts + Labor (or 3000 Hours)	2%
IC sweeper/scrubbers	Ninety days	Six months	Two years/2000 hrs	Two years/3000 hrs**	2 years Parts + Labor (or 2000 Hours)	3%
IC sweepers	Ninety days	Six months	Four years/3000 hrs	Five years/3000 hrs**	4 Years Parts + 2 Years Labor (or 4000 Hours)	3%
Exceptions						
Apex series sweeper	Ninety days	One year	One year/1000 hrs	One year/1000 hrs**	2 years Parts + Labor (or 2000 Hours)	3%
6X sweeper	Ninety days	Six months	Two years/2000 hrs	Two years/2000 hours**	2 years Parts + Labor (or 2000 Hours)	3%

Tank Bladders Eight years/ no additional labor
Polypropylene plastic tanks Ten years/ no additional labor
Batteries 0-3 months full replacement, 4-12 prorated credit
Charges One-year replacement
Replacement parts Ninety days

*Two-hour cap

**Through engine manufacture. See section 3 of warranty manual for engine warranty exceptions

***Base upon dealer's certification status

Extended Warranty MUST be signed up within 30 days of delivery to End User (Dealer has 1 Year from Receiving Machine to Sign up extended Warranty)

Extended Warranty Cost is based on Invoice Price multiplied by the Percentage listed in the Extended Warranty Column

All above labor and travel reimbursed at 65 or 75% of the published shop rate.